

# SPEAKERBOX

**FREE/FREE+/BeFREE** InterCom Module



## TECHNICAL OVERVIEW

### Description and Application

SpeakerBox\_TO\_7\_1.doc

Version 7.1

December 15, 2014



[ TIPRO® ]

**TABLE OF CONTENTS**

A. GENERAL INFORMATION .....	A-1
A.1. Highlights .....	A-2
A.2. Terminology .....	A-3
A.3. Technical Characteristics .....	A-4
B. INTEGRAL PARTS AND FUNCTIONALITY .....	B-1
B.1. Microphone Amplifier .....	B-3
B.2. Handset/Headset Amplifier .....	B-3
B.3. Hands-Free Amplifier .....	B-3
B.4. Alarm/Alert Amplifier .....	B-4
B.5. Bar-Graph Display .....	B-4
B.6. Incremental Encoder .....	B-4
B.7. Mechanical Keys with LED Indicators .....	B-4
B.8. External Headset Connection .....	B-4
B.9. External Handset Connection .....	B-5
B.10. External Digital Inputs .....	B-5
B.11. Interface and Power Connection .....	B-6
B.12. Differences between Stand-Alone and Add-On Versions .....	B-7
C. OPERATION .....	C-1
C.1. Configuring Speakerbox .....	C-1
C.2. Operating Modes .....	C-2
C.3. Using Tipro USB Audio Modules .....	C-2
D. OPTIONS .....	D-1
D.1. HID Telephony Interface .....	D-1
D.2. Echo-Cancellation Circuitry .....	D-1
D.3. Goose-Neck Microphone .....	D-2
E. ORDERING CODES .....	E-1
E.1. Module .....	E-1
E.2. Stand-Alone Version (Configuration) .....	E-2
F. REFERENCES .....	F-1
G. NOTICES .....	G-1
G.1. Disclaimer .....	G-1
G.2. Copyright Notice .....	G-1

## A. GENERAL INFORMATION

The **Speakerbox** (also referred to as InterCom) is a member of the modular **FREE/FREE+/BeFREE** (also referred to as **FREE**) product family. It is a USB audio device for hands-free bidirectional voice communication, which can be combined with the other family members into multifunctional consoles for various applications.

Besides the primary function (i.e. hands free voice communication) it also provides connection for an external analogue headset and handset, as well as a digital control over all audio devices (HandsFree, Headset and Handset) that share the same audio channel. The Hands-Free audio device comprises a Voice Speaker and a goose-neck microphone, along with an incremental encoder for volume control, a bar-graph multicolour LED indicator and two function keys (MIC key and HF key). Two more keys are provided for immediate loudspeaker volume control of the external headset and handset.

As a stereo audio device the Speakerbox also incorporates another speaker (so-called Alert Speaker), which is intended for alarm/alert messages from the host system.

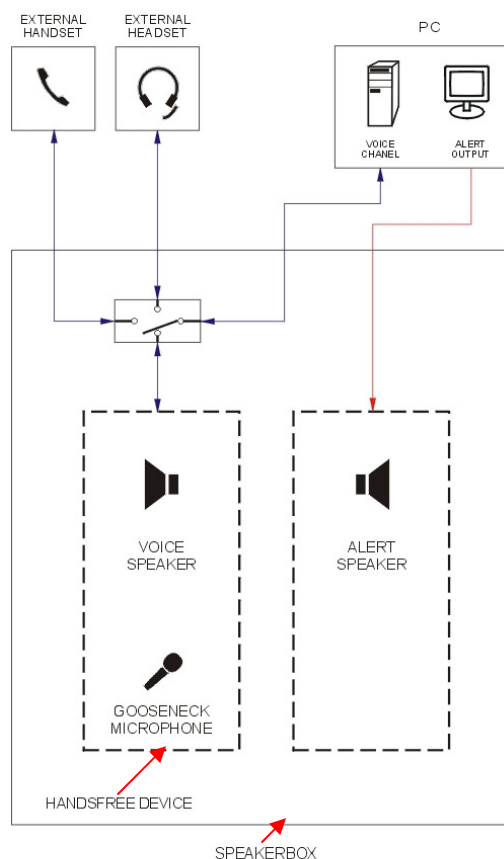

**Figure A.1 Speakerbox – Simplified Block Diagram**

All embedded functions (switching between the devices, volume control, side-tone feature, noise gating and compression of microphone signals ...) are programmable via ChangeMe software and/or controllable by the application software. By default the module operates as per predefined state diagram (see chapter C) in so-called “Off-Line” operating mode, but can be at any time switched (respective Windows API has been provided for) under total control of the application software i.e. into the “On-Line” operating mode.

Integrated mechanical keys (6 of them) operate as programmable USB keys (i.e. emulating user definable input from a standard computer keyboard), what enables seamless integration of these features into existing application software without any intervention in the code. Once configured (using ChangeMe), the module does not require any proprietary software to operate, but rather generic USB HID keyboard (for mechanical keys) and USB audio (for voice) drivers of the operating system in use.

As all other **FREE** add-on modules, the Speakerbox module requires a Tipro USB controller to operate. The controller is normally integrated into another module (e.g. a touchcomputer or a touchmonitor module) within the same modular configuration. Alternatively, for a stand-alone application, a special variant of the module with integrated controller (TM-FMx) is also available (see Chapter B.12).

## A.1. Highlights

### APPLICATIONS

- ◆ dispatcher terminals
- ◆ banking & trading consoles
- ◆ multifunctional control panels
- ◆ digital telephony (e.g. Voice over IP) devices

### CONCEPT AND MODULARITY

- ◆ ergonomic hands-free voice communication device
- ◆ combination of a USB audio device and an HID keyboard
- ◆ plug & play operation with generic USB audio and USB HID keyboard drivers
- ◆ optional emulation of HID Telephony device
- ◆ optional acoustic echo-cancellation circuitry with a digital signal processor (echo-canceller)
- ◆ configurable switching between the hands-free and external analogue audio devices
- ◆ separate output for alarm/alert tones/messages
- ◆ integrated acoustic shock protection
- ◆ external analogue audio devices (handset and headset) effectively converted into the corresponding digital (USB) devices

- ◆ combinable with other **FREE** add-on modules (e.g. handsets, touchcomputers, touchmonitors, keypads ...) into multifunctional terminals
- ◆ stand-alone operation as a **FREE** module with integrated Tipro USB controller

#### PROGRAMMABILITY

- ◆ all implemented audio functions are programmable
- ◆ six programmable mechanical keys

#### VERSATILITY

- ◆ user configurable predefined operating mode (“Off-Line”)
- ◆ dynamically controlled operation by the application software (“On-Line”)
- ◆ keys with dedicated hardware function and/or programmable keys
- ◆ LED indicators with dedicated hardware function and/or programmable indicators

### A.2. Terminology

As the Speakerbox is a rather complex audio device, certain terms need to be clearly defined in order to avoid misunderstanding. The following definitions do not necessarily represent generally accepted technical facts, but merely a nomenclature explanation in order to help understand the document properly.

- ◆ **audio device** – a device comprising a transducer to turn an electric signal into a sound (loudspeaker), as well as a transducer to turn a sound pressure into an electric signal (microphone), both along with the associated electronic circuitry
- ◆ **mono audio device** – an audio device comprising one loudspeaker and one microphone – same as **audio device**
- ◆ **stereo audio device** – an audio device comprising two loudspeakers (left and right) and one microphone
- ◆ **audio output** – output audio signal of a computer to be connected to the Speakerbox (it is input signal to the Speakerbox)
- ◆ **audio input** – input audio signal of a computer to be connected to the Speakerbox (it is output signal of the Speakerbox)
- ◆ **audio channel** – a pair of one input and one output audio signal addressed to a mono audio device
- ◆ **mono audio channel** – same as **audio channel**
- ◆ **stereo channel** – a combination of one input and two output (left and right) audio signals addressed to a stereo audio device
- ◆ **voice channel** – the pair of input audio signal and left output audio signal
- ◆ **alarm output (alert output)** – right output audio signal
- ◆ **USB audio output** – USB (digital) output audio signal of a computer

- ◆ **USB audio input** – USB (digital) input audio signal of a computer
- ◆ **USB audio port** – regular USB downstream port of a computer used to transmit two USB output signals (left and right) and to receive one USB input audio signal

### A.3. Technical Characteristics

#### ELECTRICAL

- ◆ **power supply (analogue circuitry)**:  $12V \pm 5\%$  (via Tipro Power Bus from Powered FREE+ 15 Touchmonitor or BeFREE 15 Touchcomputer or alternatively from an external power supply, e.g. TM-VPB)
- ◆ **power supply (digital circuitry)**:  $5V \pm 5\%$  (from Tipro controller via Tipro bus)
- ◆ **current consumption (analogue circuitry)**: up to 600 mA (300 mA<sub>TYP</sub>), depending on the actual volume settings
- ◆ **current consumption (digital circuitry, TM-FSU & TM-FSC)**: up to 100 mA (50 mA<sub>TYP</sub>)
- ◆ **current consumption (digital circuitry, other versions)**: up to 150 mA (75 mA<sub>TYP</sub>)
- ◆ **control interface**: TIPRO bus (Speakerbox as standard add-on **FREE** module – TM-FS<sub>x</sub>)
- ◆ **control interface**: USB (Speakerbox as **FREE** module with integrated Tipro USB controller – TM-FM<sub>x</sub>) – operating as a generic HID Keyboard Device and optionally as an HID Telephony Device (see Chapter D.1)
- ◆ **audio interface**: USB – operating as a generic USB Audio Device
- ◆ **power connectors**:
  - **Tipro Power bus connector**: 10-pin Micro-MaTch receptacle (female) on the PCB - to power Speakerbox from Powered FREE+ 15 Touchmonitor or BeFREE 15 Touchcomputer
  - **Audio & Power connector**: RJ 8P/8C in the bottom part of the housing - to power Speakerbox from an external 12V Power Supply (see Chapter B.10)
- ◆ **interface connectors**:
  - **left-hand side Tipro bus connector**: 6-pin Micro-MaTch header (male) at the end of a 100 mm long ribbon cable
  - **right-hand side Tipro bus connector**: 6-pin Micro-MaTch receptacle (female) on the PCB
  - **Audio & Power connector**: RJ 8P/8C in the bottom part of the housing (see Chapter B.10)

## MECHANICAL

- ◆ **casing:** plastic ABS, black colour – C15
- ◆ **net dimensions:** 138 x 222 x 51 (without goose-neck microphone) (W/D/H) [mm]
- ◆ **gross dimensions** (with side-covers): 158 x 222 x 51 (W/D/H) [mm]
- ◆ **goose-neck microphone length/height:** 350±50mm
- ◆ **weight:** 700 g (approximately)
- ◆ **protection (sealing) grade:** IP 30 (according to EN 60529)

## ENVIRONMENTAL

- ◆ **operating ambient temperature range:** 0°C to +40°C
- ◆ **storage ambient temperature range:** -10° C to +50°C
- ◆ **relative humidity range:** 20% to 80% (non-condensing)

## AUDIO

- ◆ **Loudspeakers**
  - two in parallel within the left output
  - two in parallel within the right output
  - type: dynamic
  - rated power: 2 W
  - output sound pressure level (SPL): 85 dB ± 3 dB @ 1 W @ 1 kHz @ 0.5 m distance
- ◆ **Goose-neck Microphone**
  - type: electret condenser, unidirectional
  - max input: 120 dB SPL
- ◆ **Analogue amplifiers**
  - designed to meet wide-band IP telephony standards
  - frequency pass-band: (100 Hz - 8 kHz) TYP
  - output power: 4 x 1 W (2 x 2 x 1 W)
- ◆ **USB Audio Codec**
  - model: Texas Instruments PCM 2902x
  - USB Interface: full-speed
  - resolution: 16-bit Delta-Sigma ADC and DAC
  - sampling rates (ADC): 8, 11.025, 16, 22.05, 32, 44.1, 48 kHz
  - sampling rates (DAC): 32, 44.1, 48 kHz
  - recommended data format: **16-bit** (rather than 8-bit), **stereo** (rather than mono)

---

**MECHANICAL KEYS****◆ keyswitch**

- model: Cherry MX
- key travel: 3.6mm to 4.0mm total,  $(2 \pm 0.6)$  mm pretravel
- actuating force:  $(60 \pm 20)$  cN
- reliability (Mean Cycles To Failure): MCTF = 1 billion ( $10^9$ ) press/release cycles (50 million is guaranteed minimum)

**◆ keycaps**

- construction: separate body and cover
- size: single
- keycap bodies (with cut-out for LED): CN15 black colour
- keycap covers: transparent
- key legends: pictograms printed on a transparent paper, underneath keycap covers

## B. INTEGRAL PARTS AND FUNCTIONALITY



**Figure B.1 Speakerbox Operator Interface**

Figure B.2 shows the functional block diagram of the Speakerbox. The voice channel of the computer (left output audio signal and input audio signal) is routed to the selected mono audio device that can be Hands-Free, the external Headset or the external Handset. Only one audio device can be active at a time. The Alert Speaker is permanently connected to the Alert/Alarm channel of the computer. The Voice Speaker and the Alert Speaker are physically/electrically realized as two loudspeakers in parallel to double the output volume.

All signals undergo certain signal processing inside the Speakerbox. The processing includes analogue to digital and digital to analogue conversion (block “USB codec”), conditioning (amplification, attenuation, filtering ...), sensing and switching. The complete processing is programmable via ChangeMe software utility and can be dynamically changed during operation in the so-called On-Line operating mode.

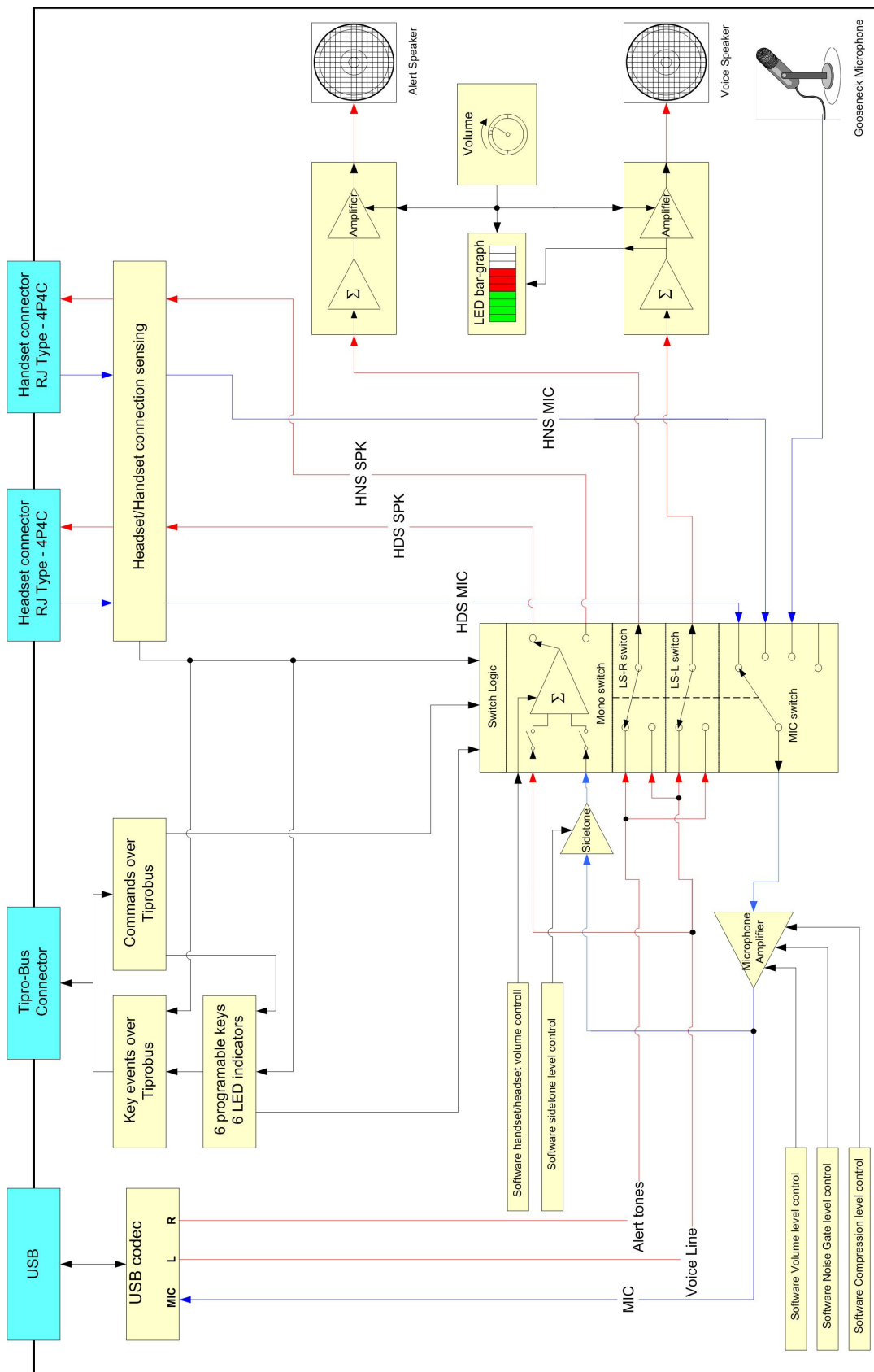

Figure B.2. Speakerbox – Functional Block Diagram

### **B.1. Microphone Amplifier**

This is a logarithmic audio amplifier with programmable gain, noise gating threshold and compression ratio. It processes microphone signal of the currently selected audio device: Hands-Free (goose-neck microphone), Headset or Handset. The noise gating feature enables ambient noise to be suppressed. All sounds below the threshold are removed inside the amplifier, so with a higher threshold the microphone needs to be used closer to the mouth and speech needs to be louder to get through the amplifier. The compression feature enables compression of the output signal dynamics in order to minimize the difference between soft/low and loud speech. The amplifier is also capable of limiting extremely loud speech thus preventing distortion and popping. The overall gain can be even lower than one (i.e. attenuation) as well as equal to zero (i.e. totally muted input). The Hands-Free device comprises an additional microphone preamplifier to provide for adjustment of the goose-neck microphone range.

### **B.2. Handset/Headset Amplifier**

This is a linear audio amplifier with programmable gain that drives the loudspeaker of the currently active external audio device, either Headset or Handset. It is also a summing amplifier that can add a part of the microphone signal to the output signal for the loudspeaker (so-called “side-tone” feature). The “side-tone” feature is essential to the user of the Handset/Headset as it provides an immediate (without a delay) audio feedback. The side-tone level is also programmable. The gain of this amplifier (i.e. volume of the loudspeaker inside handset and headset) can be adjusted by the user in normal operation via two mechanical keys (Volume Up and Volume Down) at the front left-hand side of the module. The selected level is immediately displayed at the bar-graph display in orange colour (10 volume levels + mute).

### **B.3. Hands-Free Amplifier**

This is a linear audio amplifier with programmable gain that drives the Voice Speaker. The gain of this amplifier (i.e. volume of the Voice Speaker) can be adjusted by the user in normal operation via the incremental encoder (i.e. endless digital potentiometer) at the front right-hand side of the module. The selected level is immediately displayed at the bar-graph display in green colour (20 volume levels + mute). The amplifier can deliver up to 2 W (2 x 1 W) of electric power to the Voice Speaker.

#### **B.4. Alarm/Alert Amplifier**

This is a linear audio amplifier with programmable gain that drives the Alert Speaker. The gain of this amplifier is normally equal to the gain of the Hands-Free amplifier, but it can also have a separate response characteristic to the position of the incremental encoder. This way, for instance, the Alert Speaker can be held at a constant volume level while increasing/decreasing volume level at the Voice Speaker. The amplifier is capable to deliver up to 2 W (2 x 1 W) of electric power to the Alert Speaker.

#### **B.5. Bar-Graph Display**

It comprises 10 three-colour (red, green and orange) LEDs to display the level of the left output signal and the level of the microphone signal (a sum of the two) as VU meter (red colour), or the gain of the Handset/Headset amplifier (orange colour) or the gain of the Hands-Free amplifier (green colour). By default it constantly operates as a VU meter. If a rotation of the incremental encoder has been detected it automatically displays the gain of the Hands-Free amplifier. If a press of Volume Up or Volume Down key has been detected it automatically displays the gain of the Handset/Headset amplifier.

#### **B.6. Incremental Encoder**

This is an endless digital potentiometer used for immediate volume control of the Voice and Alert Speakers. It has 24 detents per revolution. Every single detent changes the volume for one step up or down, but only every second one is represented by one LED in the Bar-Graph display in green colour.

#### **B.7. Mechanical Keys with LED Indicators**

All six keys are regular programmable keys, but four of them (HF key, MIC key, Volume Up key and Volume Down key) have also additional predefined functions.

The HF key controls the Hands-Free operation (see Chapter C.2). The internal LED is illuminated while the hands-Free mode is active.

The MIC key controls the Goose-neck microphone (see Chapter C.2). The internal LED is illuminated while the microphone is active.

The Volume Up and Volume Down keys control the gain of Handset/Headset loudspeaker amplifier.

#### **B.8. External Headset Connection**

The external headset to be connected to the Speakerbox can be any analogue headset with an electret condenser microphone and a dynamic loudspeaker, providing that the

audio connector matches the connector of the Tipro analogue handset (see Figure B.3 and Reference [1]). The respective connector is accessible from the rear side of the module and is labelled by a pictogram (see Figure B.4).

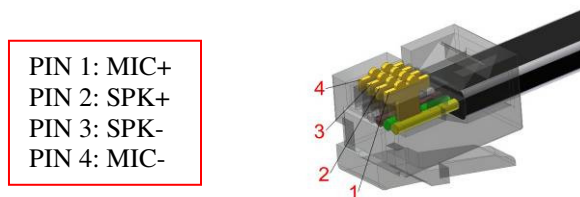

**Figure B.3 External Handset/Headset Connector and Respective Signals**

### B.9. External Handset Connection

The external handset can be any of the standard Tipro analogue handsets (e.g. TM-HHA-6A – see Reference [1]) with PTT/PTM key (PTT is acronym of Push To Talk, PTM of Push To Mute). The respective connector is accessible from the rear side of the module and is labelled by a pictogram (see Figure B.4).



**Figure B.4 Speakerbox Rear View – External Audio Device Connections**

### B.10. External Digital Inputs

The external handset and headset connections can be alternatively used as digital inputs for an external PushToTalk switch/pedal. The respective analogue microphone inputs between PIN 1 (positive polarity) and PIN 4 (negative) polarity can accept galvanically isolated contact (normally open) of a mechanical switch or an opto-isolator (collector to PIN 1, emitter to PIN 4), as shown in the Figure B.5.

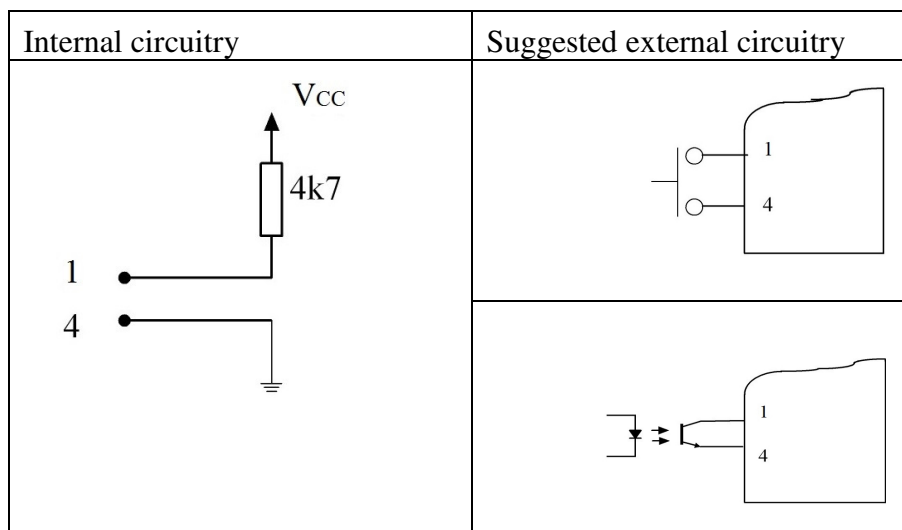

**Figure B.5 External Digital Inputs**

**B.11. Interface and Power Connection**

As shown in Figure B.6 the Interface & Power connector (RJ 8P/8C) is accessible from the bottom part of the housing. The corresponding cable is split at the computer side, one end for USB and the other for a power supply connection.

As a rule, the Speakerbox requires 12V power from an external power supply, e.g. TM-VPB. The only exception to the rule is Speakerbox as a standard add-on module (TM-FSx) used in a **FREE** configuration along with a BeFREE 15 touchcomputer or a Powered FREE+ 15 touchmonitor, where the touchcomputer or the touchmonitor provides power to the rest of the configuration via Tipro Power Bus. In this case the external cable has only one end (USB) at the computer side.

Examples of power and signal connections are presented in Figure B.7 and Figure B.8 for the two representative modular configurations (InterCom and Terminal/Console).

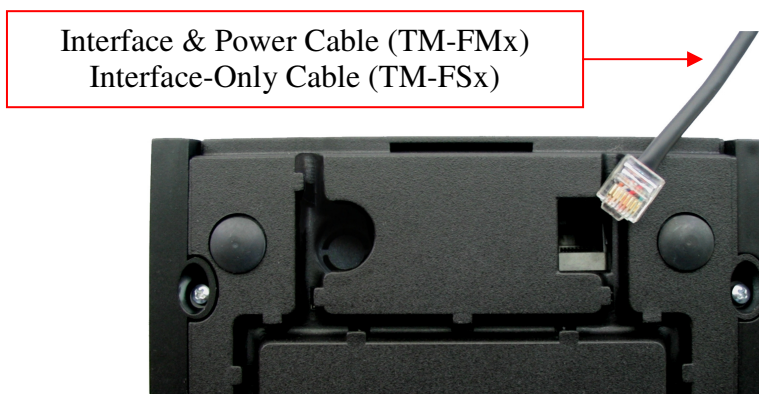

**Figure B.6 Speakerbox Bottom View (Detail) – Interface & Power Connection**

**B.12. Differences between Stand-Alone and Add-On Versions**

The TM-FMU is a Stand-Alone version and a functional superset of the TM-FSU Add-On version of the module. It additionally incorporates a Tipro USB controller with a built-in bus-powered hub (one downstream port is occupied by the Tipro controller, another one with the USB Audio Codec).

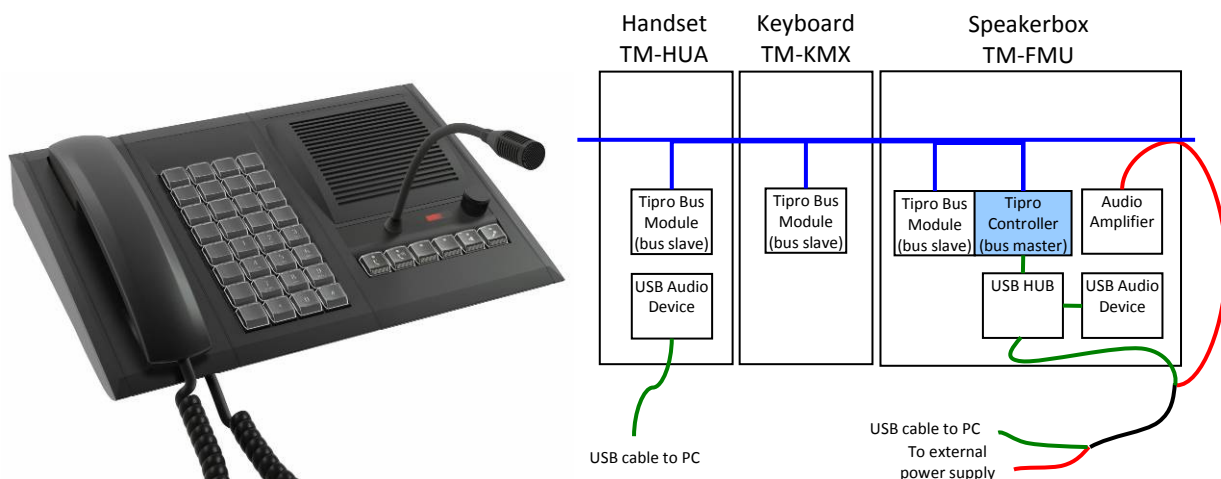

**Figure B.7 InterCom Configuration with TM-FMU Stand-Alone Module**

Figure B.7 presents a block diagram of the Stand-Alone Speakerbox when integrated into a typical modular **InterCom** configuration (i.e. a configuration without a touchcomputer/touchmonitor module). The block diagram of the Add-On Speakerbox is shown in Figure B.8, along with other modules in a representative **Terminal/Console** configuration (i.e. a configuration comprising a touchcomputer/touchmonitor module).

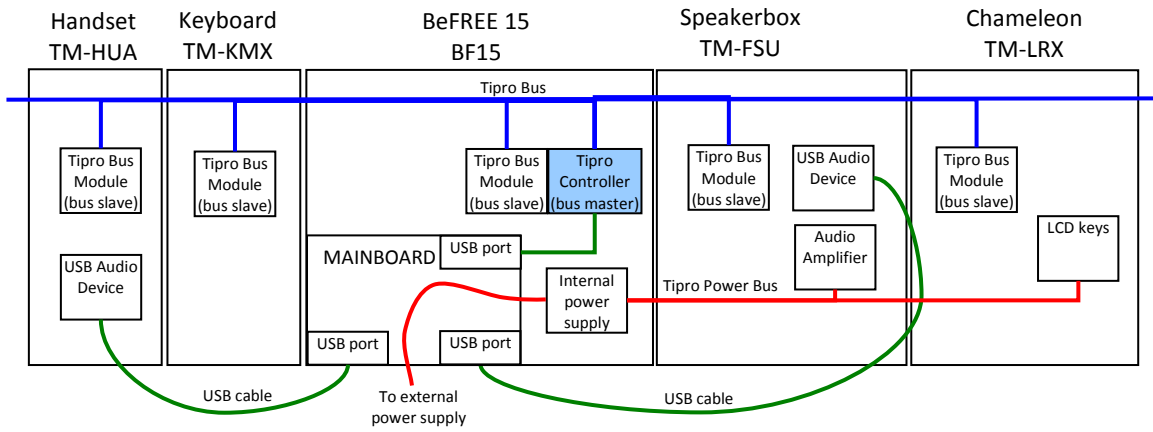

**Figure B.8 Terminal/Console Configuration with TM-FSU Add-On Module**

## C. OPERATION

### C.1. Configuring Speakerbox

The Speakerbox is a relatively complex device with a number of programmable settings/parameters provided for users to configure in accordance to the particular application. To enable this feature Tipro supplies the respective programming utility (**ChangeMe**) which operates only under Windows operating systems. It assists users to define own set of parameters, save them into a file (for possible replication in the future) and program into non-volatile memory of the device.

The USB Speakerbox module implements a standard USB audio Codec. Therefore no device specific driver is needed for the module to operate under Windows operating systems. However, it may or may not be the case with other operating systems, such as Linux, where it depends on the actual distribution, kernel version, etc.

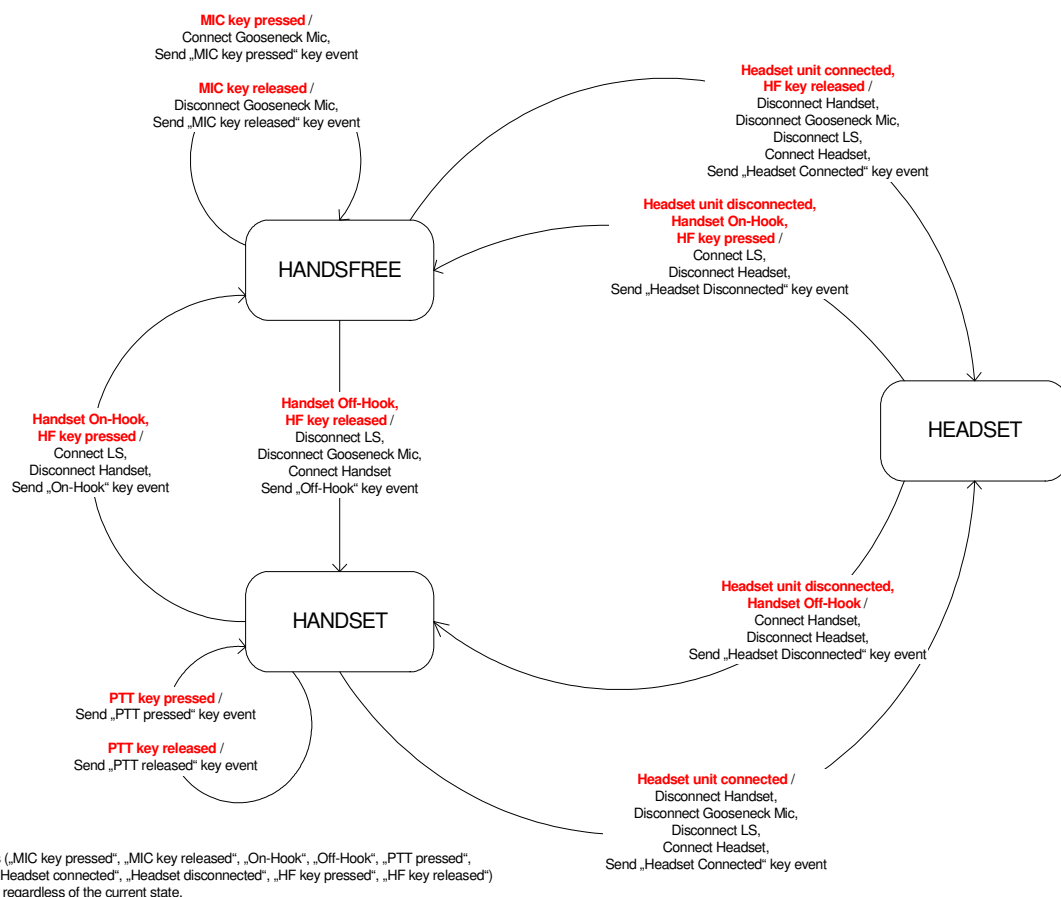

Figure C.1. Speakerbox – State Diagram (Off-Line Operating Mode)

## C.2. Operating Modes

**Off-Line** is the default mode where the operation is controlled from within the module, applying the parameters/settings previously defined by ChangeMe programming utility.

As represented in the state diagram (Figure C.1), the Speakerbox can remain in one of the three possible states: HANDSFREE, HEADSET or HANDSET. Since the headset is the highest priority audio device, the default state is HEADSET if an external headset is connected. The lowest priority state is HANDSFREE.

Arrows in the state diagram define possible transitions between the states. Each transition is described by the event which may cause it to happen (text in red colour) and the actions to be taken upon the event (text in black colour).

In the **On-Line** operating mode the host computer controls the complete operation of the module. This mode is intended for advanced users having control over the application software design. The respective Windows API (**HID API**) is available, as well as the associated technical documentation.

## C.3. Using Tipro USB Audio Modules

Besides the USB Speakerbox Tipro also offers other USB audio modules (e.g. Handsets, Touchmonitors with integrated loudspeakers) that can be joined into a single **FREE** configuration. On the other side, Windows operating systems present each of them as a **USB Audio Device**. In order to enable independent addressing and differentiation, each type of **FREE** audio module (Handset, Speakerbox, Touchmonitor) has a different USB product ID.

However, Tipro can not guarantee that the actual Product ID of the USB Speakerbox module (or any other individual **FREE** USB audio module) will not change in the future, as this depends on the USB Codec IC vendor(s) who reserve the right to change it.

## D. OPTIONS

### D.1. HID Telephony Interface

Actual statuses (pressed/released) of the six mechanical keys are normally reported to the host computer as a programmable sequence of keystrokes generated by a standard USB keyboard, this way emulating a generic HID Keyboard Device. An example of the application can be found in the Reference [8] (“Hook and PTT in Software”).

Since nearly all operating systems are capable of accepting standard USB keyboard input and nearly every application software expect the operator to use it, this concept typically enables Tipro Modular Dispatcher Terminals to be integrated into the existing software environment without any intervention in the code.

However, certain software applications are designed to enquire on the status of the keys rather than capturing the respective keyboard events. In such cases the HID Telephony Interface is applicable. It is supported by the special Speakerbox variants (TM-Fx**T**) that send status reports only when specifically addressed to, what is different to HID Keyboard devices that report automatically to the respective driver whenever a change in status occurs. TM-Fx**T** Speakerboxes represent supersets of the standard TM-Fx**U** counterparts, being capable to emulate HID Telephony and HID Keyboard device concurrently.

All Speakerbox variants with HID Telephony support (TM-Fx**T**) as well as the variants with integrated Tipro controller (TM-FM**x**) comprise a bus-powered USB hub and therefore have to be connected to the root hub of the host computer (e.g. BeFREE 15)

### D.2. Echo-Cancellation Circuitry

Acoustic echo is a physical phenomenon inherent to hands-free devices (such as Intercom) in full-duplex mode, so it needs to be suppressed and/or cancelled. This is normally implemented in the application software through specific signal processing routines. Alternatively, it can be achieved in the hardware using a digital signal processor. Basic properties of the optional (see Chapter E.1 for details on the respective Ordering Code) Echo-Cancellation circuitry (Echo-Canceller) are listed below.

- ◆ **performance:** full-duplex
- ◆ **sampling rate:** 16 kHz
- ◆ **acoustic echo-cancellation:**  $\geq 40$  dB
- ◆ **latency:**  $\leq 50$  ms
- ◆ **power consumption:** 250 mW<sub>TYP</sub>

### **D.3. Goose-Neck Microphone**

By default, the goose-neck microphone is an integral part of the Speakerbox, but it can be optionally omitted. See Chapter E.1 for details on the respective Ordering Code.

## E. ORDERING CODES

### E.1. Module

1
2
3
4
5  
**T M - F S U - C15 - xxx**

#### 1 – Type

**F** – Speakerbox module (HandsFree or InterCom)

#### 2 – Configuration

**S** : Standard **FREE** add-on module

**M** : Stand-alone **FREE** module with Tipro USB controller

#### 3 – Audio Interface and Integrated Options

**U** : USB

**V** : USB, no goose-neck microphone

**C** : USB, integrated Echo-Canceller

**T** : USB with HID Telephony Device

**Z** : USB with HID Telephony Device, no goose-neck microphone

**G** : USB with HID Telephony Device, integrated Echo-Canceller

#### 4 – Housing Colour

**C15** – black is the standard colour

#### 5 – Custom Version

Three-digit number reserved for product customizations. It is omitted in case of standard version.

#### Note 1:

Speakerbox interface & power cable is considered to be an integral part of the module and shall not be ordered separately.

#### Note 2:

Speakerbox requires 12V power supply to operate (see Chapter B.11 for details). The respective AC/DC adapter is included in the modular configurations where needed and shall not be ordered separately.

## E.2. Stand-Alone Version (Configuration)

1      2    3    4    5      6      7  
T M C - F M C V - C15 - 000

**1 – C** – Configuration – Complete Device

**2 – F** – Speakerbox Module (TM-FMx)

**3 – M** – Integrated Controller (Master) Module

**4 – C** – Interface Cables Included

**5 – V** – Side Covers (End Caps) and/or AC/DC Adapter (Power Supply) Included

### **6 – Housing Colour**

**C15** – black is the standard colour

### **7 – Custom Version**

Three-digit number reserved for product customizations. It is omitted in case of standard version.

### **Note 1:**

Stand-Alone Speakerbox requires 12VDC power supply to operate. The respective AC/DC adapter is included in the packaging, along with the EU power cord.

## F. REFERENCES

1. “HANDSET” – Technical Overview
2. “BeFREE 15” - Technical Overview
3. “BeFREE 10” - Technical Overview
4. “POWERED FREE+ 15” – Technical Overview
5. “ChangeMe” – User’s Manual
6. “HID API” – Reference Manual
7. “Modularity Demystified” – “Dispatching Hints & Tips” White Paper – Issue No. 001
8. “Hook & PTT in Software” – “Dispatching Hints & Tips” White Paper – Issue No. 004
9. “HID Telephony Interface” – “Dispatching Hints & Tips” White Paper – Issue No. 005

## **G. NOTICES**

### **G.1. Disclaimer**

Information furnished by Tipro is believed to be accurate and reliable. However, Tipro makes no representations or warranties regarding the accuracy or completeness of the contents of this document and reserves the right to make changes to specifications and product descriptions at any time without notice.

### **G.2. Copyright Notice**

© 2007-2014 Tipro. All rights reserved. Trademarks and registered trademarks are the property of their respective owners.